



DUROSTAMP



PRESS BRAKE TOOLING USA

DTW.100-A30-V8-R2.5

H 3.94" - 100.00 mm - 30°

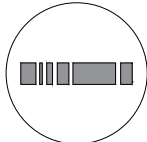

Type SF3

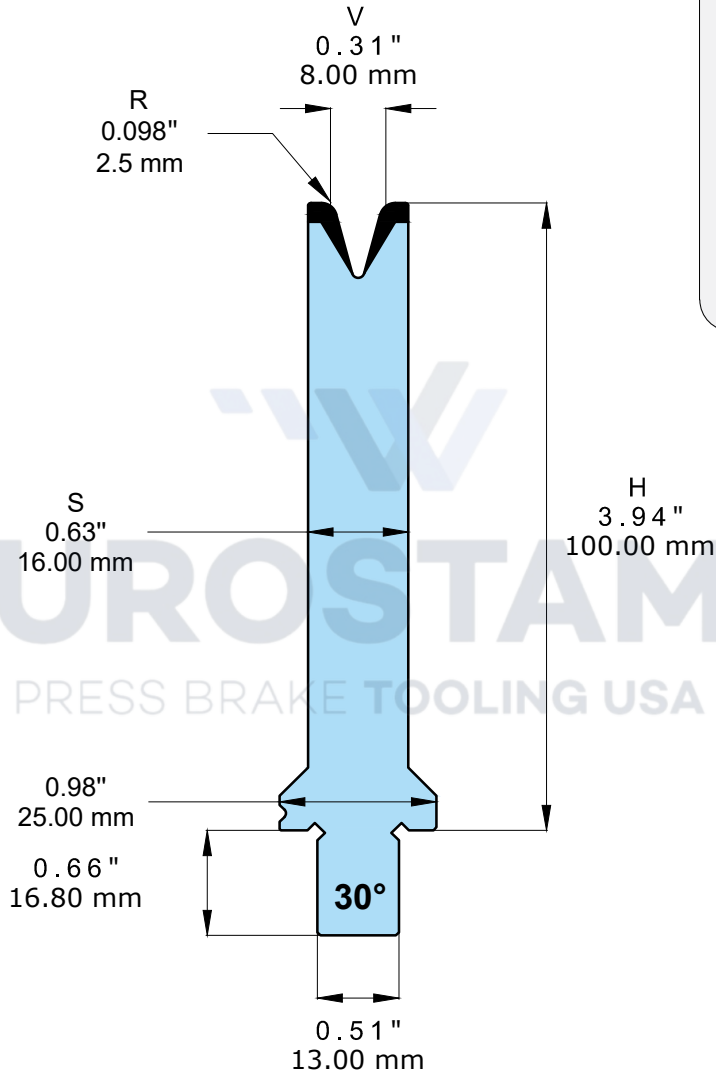

42CrMo4
 Bonificato
 Tempered
 Edge
 55-60 HRC
 MAX LOAD
 10.65
 TONS / FT
 35.00
 TONS / M

V = 0.31" / 8.00 mm / 30°

332.810.02 - SC3 20.28" / 515 mm 16.31 lbs / 7.40 kg

332.810.02 - SF3 21.65" / 550 mm 17.42 lbs / 7.90 kg



DTW.100 SERIES
WILA STYLE

