

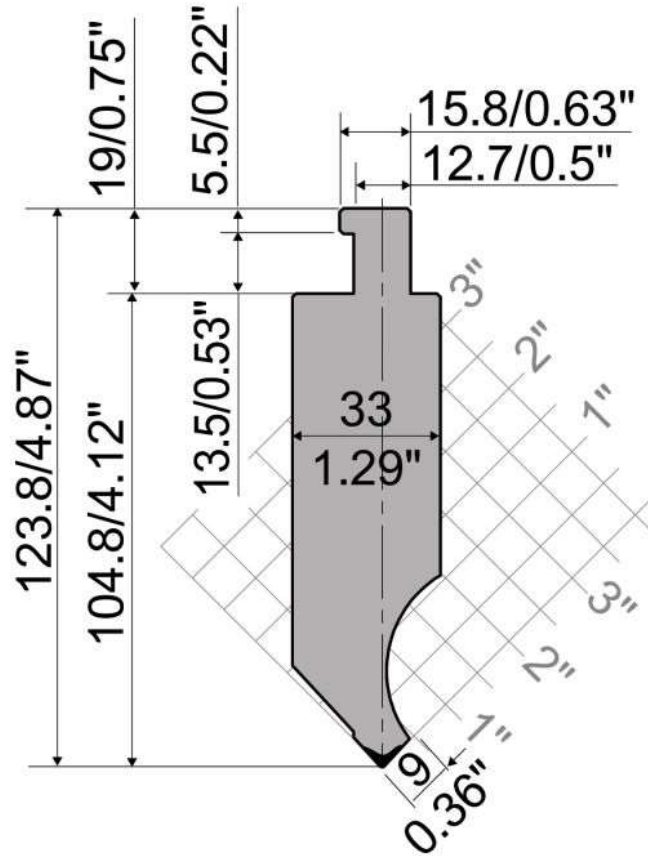

**DUROSTAMP**  
PRESS BRAKE TOOLING USA



**ASPT.106-A85°-R3.2**



<b>32.99"</b>	838 mm
<b>SC 16.34"</b>	415 mm
<b>SF 31.69"</b>	805 mm
Segmented	9 Pc

<b>46.30 lb</b>	21.00 Kg
<b>22.93 lb</b>	10.40 Kg
<b>44.53 lb</b>	20.20 Kg
Horn Type	7X

<b>Radius</b>	0.126"	3.20 mm
<b>C45</b>	30.23 T/Ft	90.00 T/M

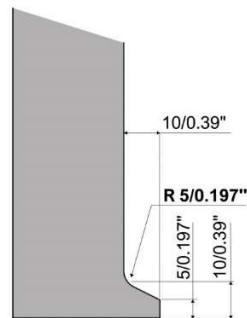
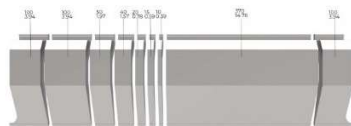

**PUNCH / ASPT SERIES**  
**AMERICAN STYLE**

